

## STATIC LOAD DATA

### BALL & RING SPHERICAL BEARINGS

#### MATERIAL SINTERED BRONZE

- All load data was obtained by statically testing a large sample size of bearings of each specific size.
- The static load limit is the main value that was obtained by testing. It is the force it takes for the bearing ball's bore diameter to change 1/2 total tolerance allowed.
- The bore diameter is within the tolerance up to this force. It is not recommended to exceed this value.
- The static load rating is the max force the ball & ring assembly can take before failure due to either the ball cracking or permanent set created in the ball causing it to lock in place.
- Due to the wide variety of scenarios and by-use cases of the bearing assemblies, a dynamic load rating cannot be found directly.
- The dynamic load rating shown was obtained by taking 1/3 the value of the static load rating.

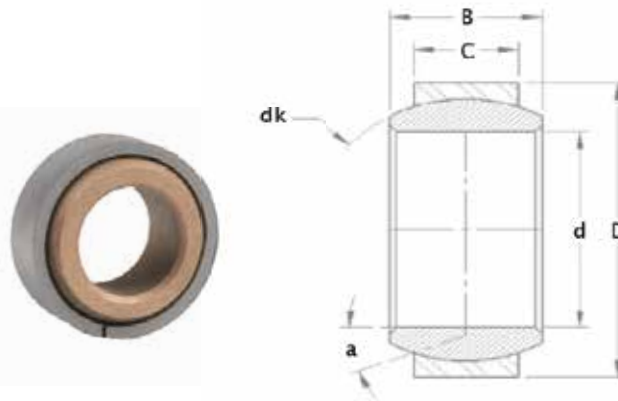

#### METRIC UNITS

Bearing Model	Nom. Bore Dia.	Min. Bore Dia.	Max Bore Dia.	Ball Dia.	Mounting Hole Dia.	Ball Height	Ring Height	Max Misalignment Rotation Angle	Dynamic Load Rating	Static Load Rating	Static Load Limit	Mass
	d(mm)			Dk (mm)	D (mm)	B (mm)	C (mm)	a (deg.)	CD(kN)	CS (kN)	Pmax Limit (kN)	m (kg)
HA												
HA4104P	6.35	6.36	6.39	14.67	16.66	9.53	6.76	36	4.450	13.354	7.173	0.010
HA4105P	7.94	7.95	7.99	14.67	16.66	9.53	6.76	29	5.518	16.550	8.740	0.008
HA4106P	9.53	9.54	9.56	14.67	16.66	9.53	6.76	22	3.903	11.712	6.230	0.007



150 Libbey Ave. Oshkosh, WI 54901  
 P: (920)-235-3710  
 F: (920)-235-4523  
 sales@triangleoshkosh.com  
 www.triangleoshkosh.com

Bearing Model	Nom. Bore Dia.	Min. Bore Dia.	Max Bore Dia.	Ball Dia.	Mounting Hole Dia.	Ball Height	Ring Height	Max Mis-	Dynamic Load Rating	Static Load Rating	Static Load Limit	Mass
	d(mm)			Dk (mm)	D (mm)	B (mm)	C (mm)	a (deg.)	CD(kN)	CS (kN)	Pmax Limit (kN)	m (kg)
HB												
HB1105P	7.94	7.95	7.99	19.06	22.23	12.70	7.92	40	6.617	19.851	12.380	0.022
HB1106P	9.53	9.54	9.58	19.06	22.23	12.70	7.92	35	6.653	19.958	12.785	0.020
HB1107P	11.11	11.13	11.16	19.06	22.23	12.70	7.92	29	6.203	18.614	11.846	0.017
HB1108P	12.70	12.71	12.74	19.06	22.23	9.53	7.95	23	5.763	17.293	10.805	0.012
HC												
HC3908P	12.70	12.71	12.75	20.32	23.81	12.70	11.13	17	8.789	26.366	15.223	0.031
HD												
HDB8	12.70	12.71	12.75	30.19	33.34	19.05	13.49	38	19.286	57.854	29.552	0.082
HDB10	15.88	15.89	15.93	30.19	33.34	19.05	13.49	31	20.225	60.671	31.230	0.092
HDB12	19.05	19.06	19.10	30.19	33.34	19.05	13.49	24	17.849	53.542	26.237	0.059
HDB14	22.23	22.24	22.28	30.19	33.34	15.88	13.49	15	14.102	42.302	19.680	0.031
HE												
HE1406P	9.53	9.54	9.58	25.41	28.58	12.70	8.71	47	9.194	27.581	15.339	0.054
HE1408P	12.70	12.71	12.75	25.41	28.58	12.70	8.71	39	10.595	31.791	17.885	0.048
HE1410P	15.88	15.89	15.93	25.41	28.58	12.70	8.71	31	11.481	34.443	19.264	0.040
HF												
HF4014P	22.23	22.24	22.28	38.00	42.86	25.40	17.48	26	21.631	64.890	42.502	0.147
HF4016P	25.40	25.43	25.48	38.00	42.86	25.40	17.48	20	23.447	70.346	45.079	0.127